

LOUSS

Lighting Emotion

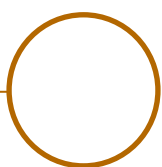

MAGMATO 200

The recessed orientable
floodlight Maxi



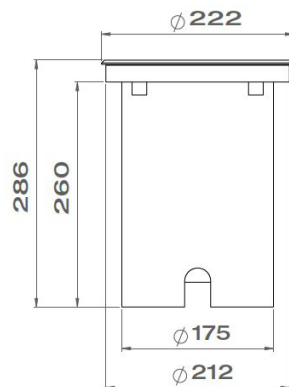
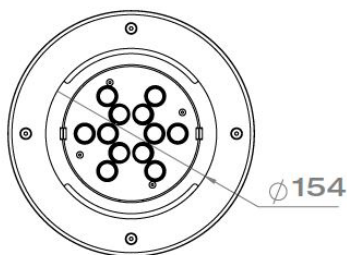
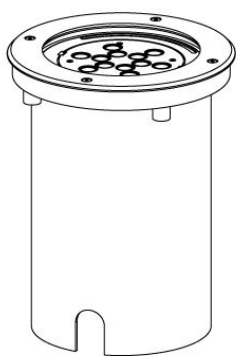

MAGMATO 200

Range	Recessed architectural floodlighting
Description	Body in cast aluminium Chisel head 20°: 316L stainless steel with 5 joules IK10 glass Dedicated recessed box Static load capacity: 2500 kg
Dimensions	External diameter: 222mm. Installation: D.212mm Height: 286mm
LED characteristics	12/18 LED: 2200K – 2700K – 3000K – 4000K – 5000K – 6500K (other LED colours upon request) 18 LED: RGBW – Twin White
Optical beam	15° - 30° - 40° - 60° - 12x50 or 18x36 elliptical (other optical beam upon request)
Connection	Delivered with 1m standard cable (more length upon request)
Integrated power supply	350mA – 500mA
LED power	350mA: 15W (12 LED) – 22W (18 LED) – 29 W (18 LED full RGBW) 500mA: 33W (18 LED)
Use limitations	The product must be installed into a ventilated area. Any use with an ambient temperature higher than the specified ambient temperature (Ta) would lead to a more rapid mortality of the product and the withdrawal of our guarantees. The drivers, if not delivered by LOUSS, must be approved before use.
Warranty	Life span: L80B10 at 50,000 hours (80% remaining flux) at 25°C ambient temperature. 3-year parts and labour warranty. The warranty does not apply to products that have been opened, modified or repaired and does not cover the effects of a wrong connection, careless, abusive handling, overvoltage, lighting injury, as well as the normal wear of the product. All products are electrically tested and received a functional burn-in.

All the connections have to be made before powering up, otherwise the luminaires could be seriously damaged.

LOUSS

Last update : 07/02/2022

Firalux & LOUSS brands

SARL, Capital 40 000€
RCS DIJON B 503 367 245
TVA/VAT n°: FR24 503 367 245
APE 4676Z

Tel. : +33 380 48 65 68
contact@louss.fr
www.louss.fr
Best group

Siège social / Head Office
PA Les Terres d'Or
Route de Saint Philibert
21220 Gevrey Chambertin - FRANCE



MAGMATO 200

Installation - Safety

It is imperative to plan a drainage of the gravel during the installation of the Magmato 200.

Plan a bigger recess than the diameter of the delivered recessed box.

Avoid installing the product in a hollow space or in a possible flooded area.

Be careful of not putting something on the recessed spot glass like a bench or chairs, *etc.*

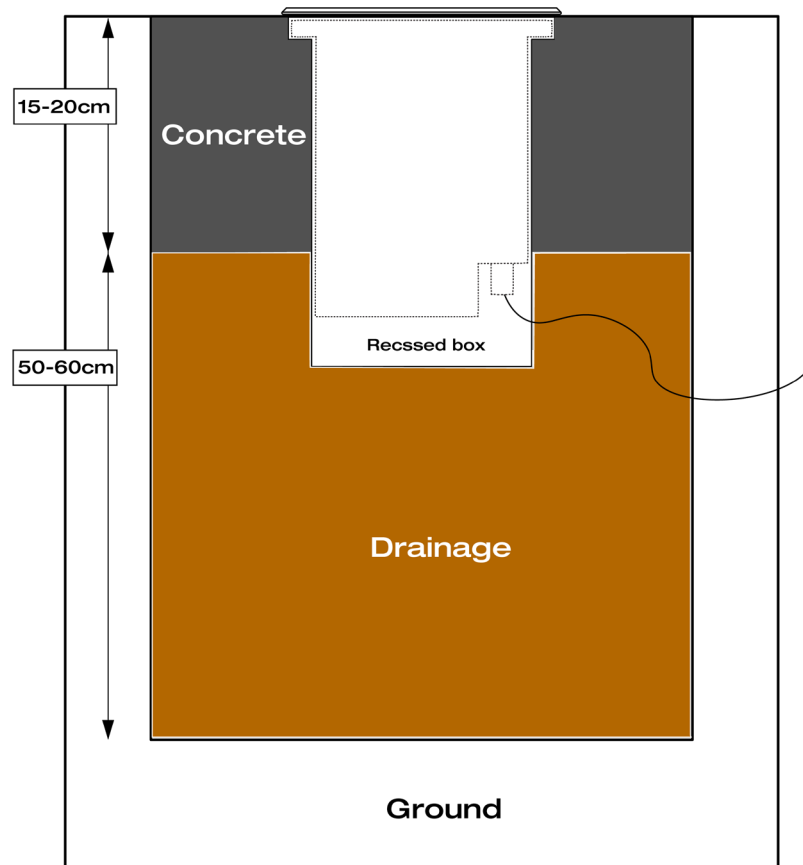

Maintenance

The access to the LED source and to the driver is made by unscrewing the front face.

During the dismantling, pay special attention to the glass and the joint. These two parts must be correctly and properly repositioned to make sure the device is waterproof.

Do not use tools such as screwdrivers to open the glass in order to avoid any pinching which might damage the joint. Let the device functioning a few minutes before closing it. The generated heat will help to evaporate any moisture and will avoid the storage of mist under the glass.

Driver's access in case of maintenance: the 230V 2P+T cable as well as the DMX In and DMX Out cables are connected on the driver on spring terminal.



MAGMATO 200

DMX lighting system connection

DMX cabling must be carried out with great care. DMX is a serial data protocol and a daisy chain topology should be used. The DMX cable must be connected to the main connection into waterproof boxes.

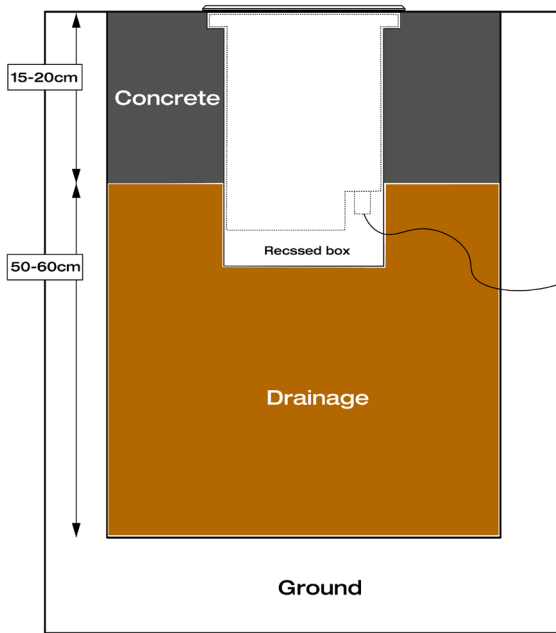

230V+DMX hybrid cable:

- Brown: Phase
- Blue: Neutral
- Yellow-green: Ground
- Integrated shielded cable:
 - Red DMX +
 - White DMX -
 - Shield

Daisy chain topology

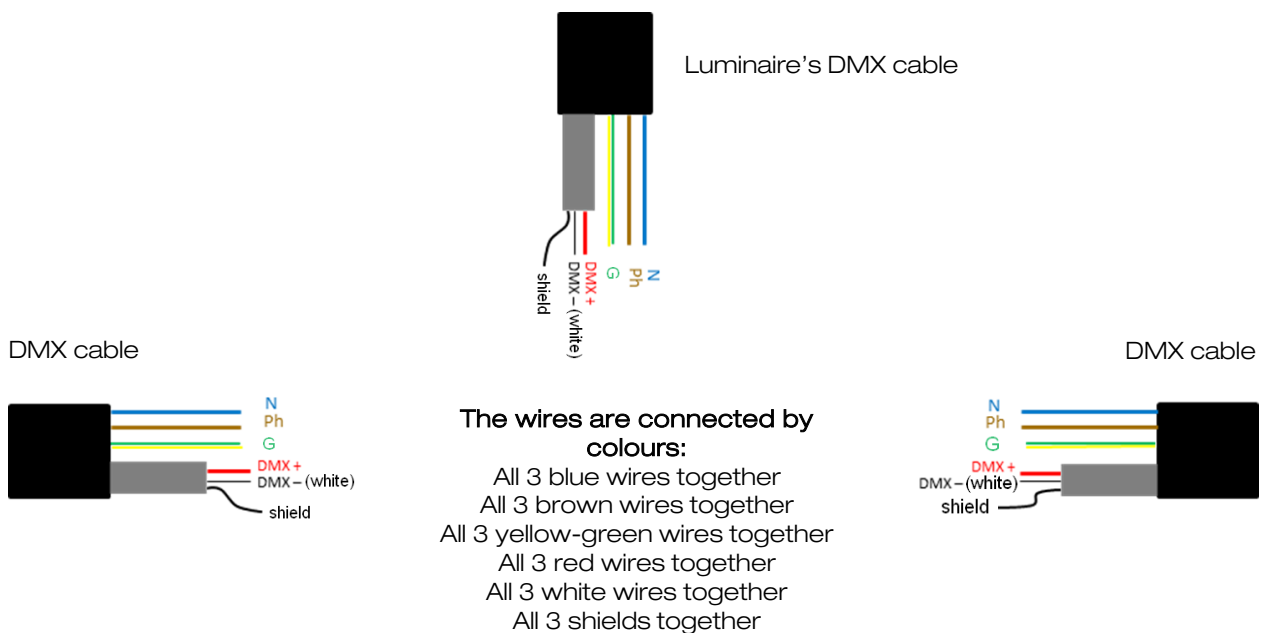



MAGMATO 200

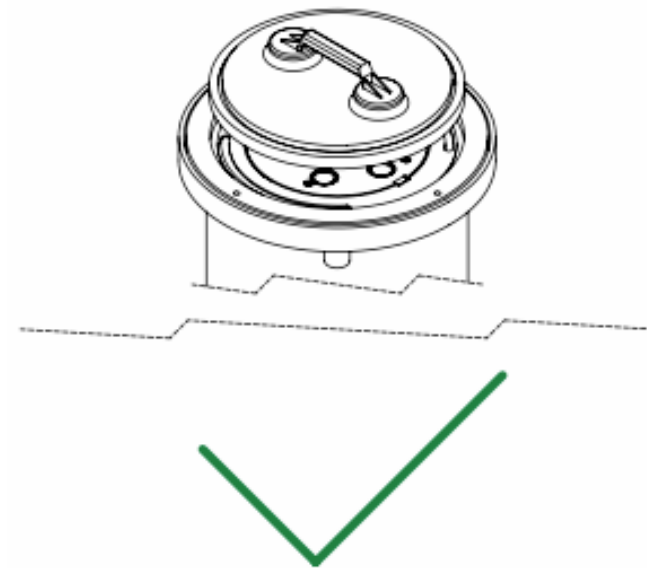

Glass removal

Use a suction cup to remove the glass to make any adjustments.

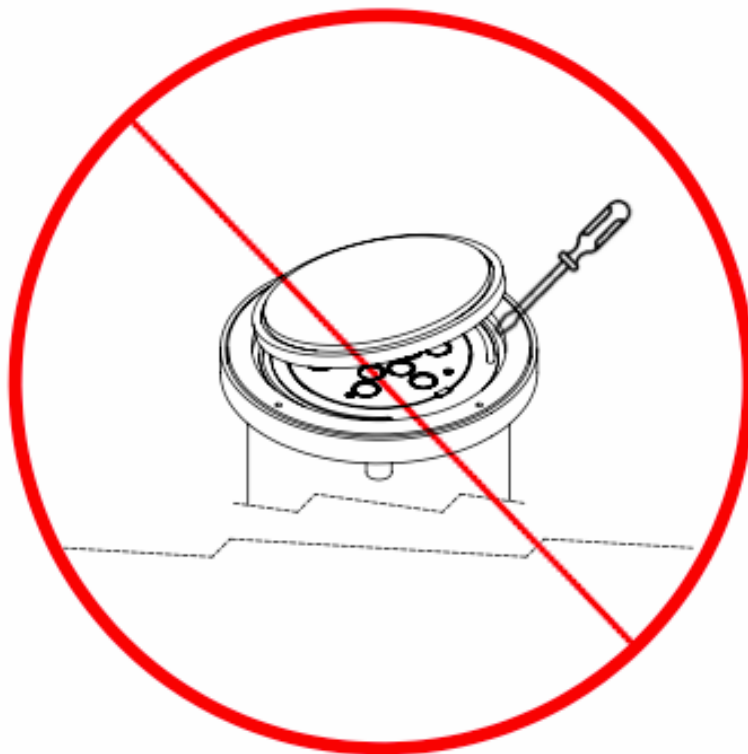

Do not use any tools to pry off, as this may damage the components and compromise sealing

Warranty claims will not be accepted if the seal is removed, damaged or displaced. or displacement of the seal

LOUSS

Last update: 05.07.2023

Firalux & LOUSS brands

SARL, Capital 40 000€
RCS DIJON B 503 367 245
TVA/VAT n°: FR24 503 367 245
APE 4676Z

Tel. : +33 380 48 65 68
contact@louss.fr
www.louss.fr
Best group

Siège social / Head Office
PA Les Terres d'Or
Route de Saint Philibert
21220 Gevrey Chambertin - FRANCE